

Mirror Head 11 Sony VPL-FH Series

Item Number: MH11-F65L Sony

The Mirror Head is a modern high-tech mirror that is digitally operated and is used as an add-on feature for projectors. It can be set to move either rapidly or slowly to project pictures, videos and texts onto any imaginable surface.

Through its high level of performance, the entire system guarantees highly accurate positioning. It is important to note that the Mirror Head is also extendable to almost every projector and a quality product made in Austria.

Static projection belongs to the past. The journey into a new visual experience begins here. Our technology paves the way to unprecedented possibilities in lighting, projection and interior design.

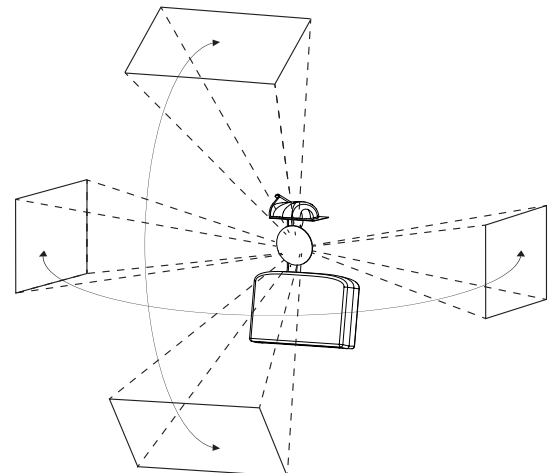



Mirror Head 11 - Sony VPL-FH Series

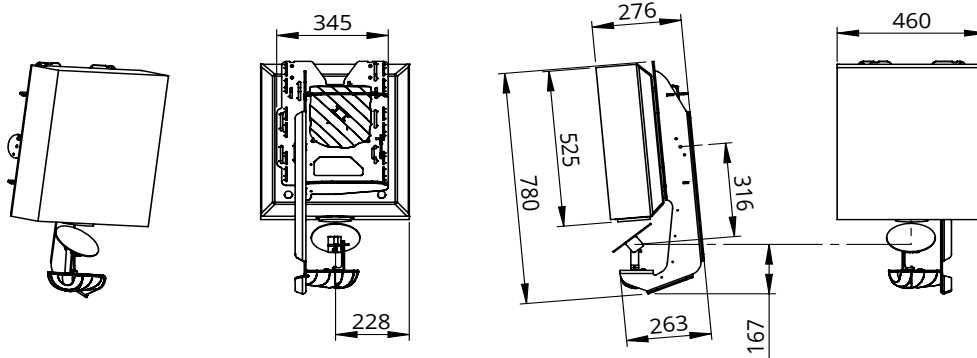

MECHANICAL SPECIFICATIONS WITH VPL-FHZ65

Fixture dimensions (W/D/H):	460mm x 276mm x 780mm
Fixture total weight:	26,8kg
Projector weight:	16,0kg
Mirror Head unit only:	10,8kg
Truss mount clamp - MHZ-BT:	2,2Kg
Wall mount clamp - MHZ-BW:	2,8Kg
Extended mount clamp - MHZ-BE:	2,7Kg
Floorstand Heavy - MHZ-BSH:	13,2Kg

ELECTRICAL SPECIFICATIONS

Input Power:	100-240V / 2-1A / 50-60Hz, Max. 10A (3-prong C14 male socket)
Output Power:	AC loop trough for projector (3-prong C13 female socket)



Caution! There are no user serviceable parts (fuse) inside this unit.

PROJECTOR COMPATIBILITY

VPL-FWZ65 / 60 WXGA (1280 x 800) 6000 / 5000 ANSI Lumen C.R.: 10000:1 Three different lenses T.R. range: 1.4 - 4.84:1	VPL-FW65 / 60 WXGA (1280 x 800) 6300 / 5200 ANSI Lumen C.R.: 2000:1 Three different lenses T.R. range: 1.4 - 4.84:1
VPL-FHZ65 / 60 / 57 WUXGA (1920 x 1200) 6000 / 5000 / 4100 ANSI Lumen C.R.: 10000:1 Three different lenses T.R. range: 1.4 - 4.84:1	VPL-FH65 / 60 WUXGA (1920 x 1200) 6000 / 5000 ANSI Lumen C.R.: 2000:1 Three different lenses T.R. range: 1.4 - 4.84:1

Due to optical reasons we do not recommend the use of the Short Throw Lens VPLL-3003, VPLL-3007, VPLL-Z3009 and VPLL-Z3010.

IMPORTANT NOTE: For information about the specifications, operations and use of the projector please read the instruction manual of the projector.
<http://www.sony.co.uk/pro/product/projectors-installation/vpl-fhz65/overview/>

OPERATION SPECIFICATIONS / FEATURES

- DMX-512 control over 14 DMX channels.
- DMX IN / OUT port (5-pin male and female XLR connectors - Neutrik).
- Art-Net™ connection (RJ45) (Art-Net™ Designed by and Copyright Artistic Licence Holdings Ltd.).
- Mirror Tilt modes: 90° & 162°
- Mirror Panmode: 180°
- High resolution micro step motors with maintenance free direct drive.
- Self calibrating mirror position for high accuracy.
- Absolut reposition accuracy <0,03°.
- Movement accuracy: Pan and Tilt from the same direction to the programmed point within approximately 0,01°.
- RS232 remote control connection for projector (D-sub 9 male).
- Flashable firmware (Mini USB).
- High resolution LED-Display for easy configuration.
- LED-Display backlight auto turn off for energy saving.
- LED-Display Flip / Flop mode for easy reading in difficult positions.
- Coated mirror for optimum reflection ~98% refraction factor.
- Optimized mirror geometry for the specific projector.
- Ambient Light LED with high power 3 Colour LEDs (18Watt total).
- High durability black powder-coating surface finishing.
- Mounting plate optimized for specific projector mounting.
- Easy to adjust mounting system.
- Heavy-use truss or wall mounting supports.
- Passive cooled system (excluding projector).
- Environmental tolerances: Ambient operating temperature range: 5°-35°C, Humidity: 20%-80% (non-condensing).
- Package includes: RS232 cable, AC-loop through cable, Quick installation guide.



To protect the environment, please try to recycle the packing material as much as possible.

