

Going beyond  
screens & monitors.



DYNAMIC PROJECTION  
INSTITUTE



## Mirror Head Panasonic PT-VZ570 Series

Item Number : MH12-VZ57L

The Mirror Head is a modern high-tech mirror that is digitally operated and is used as an add-on feature for projectors. It can be set to move either rapidly or slowly to project pictures, videos and texts onto any imaginable surface.

Through its high level of performance, the entire system guarantees highly accurate positioning. It is important to note that the Mirror Head is also extendable to almost every projector and a quality product made in Austria.

Static projection belongs to the past. The journey into a new visual experience begins here. Our technology paves the way to unprecedented possibilities in lighting, projection and interior design.

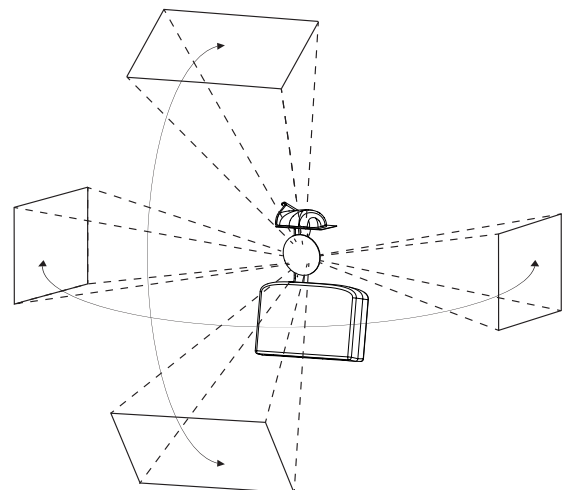



## Specifications Mirror Head Panasonic PT-VZ570 Series

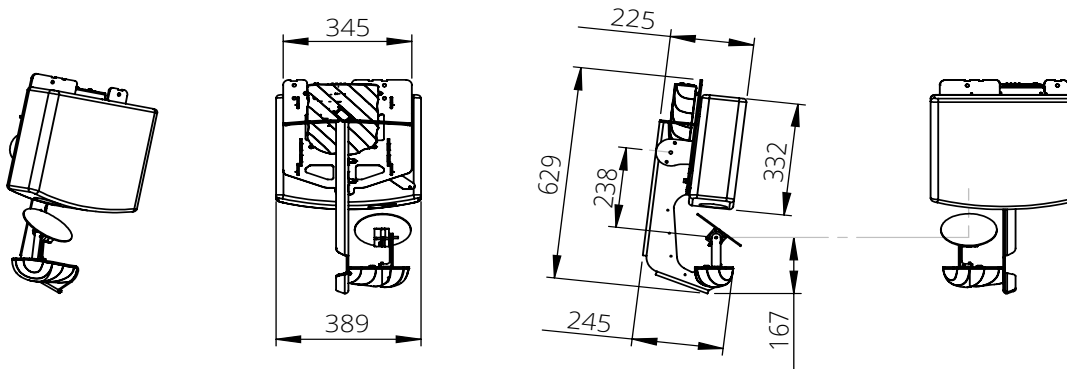

### MECHANICAL SPECIFICATIONS

Fixture dimensions (W/D/H):	389mm x 225mm x 629mm
Fixture total weight:	14,2kg
Projector weight:	4,9kg
Mirror Head unit only:	9,3kg
Truss mount clamp - MHZ-BT:	2,2kg
Wall mount clamp - MHZ-BW:	2,8kg
Extended mount clamp - MHZ-BE:	2,7kg
Floor- / Presentation stand - MHZ-BS:	3,5kg

### ELECTRICAL SPECIFICATIONS

Input Power:	100-240V / 2-1A / 50-60Hz, Max. 10A (3-prong C14 male socket)
Output Power:	AC loop trough for projector (3-prong C13 female socket ) Max. 8A - cable included

Caution! There are no user serviceable parts (fuse) inside this unit.

### PROJECTOR COMPATIBILITY

PT-VX600 / 605N  
XGA (1024 x 768)  
5500 ANSI Lumens  
C.R.: 10.000:1  
T.R.: 1.2 - 1.9:1

PT-VW530 / 535N  
WXGA (1280 x 800)  
5000 ANSI Lumens  
C.R.: 10.000:1  
T.R.: 1.2 - 1.9:1

PT-VZ570 / 575N  
WUXGA (1920 x 1200)  
4800 ANSI Lumens  
C.R.: 10.000:1  
T.R.: 1.1-1.8:1

Due to optical reasons we recommend a throw ratio over 1.4:1.

IMPORTANT NOTE: For information about the specifications, operations and use of the projector please read the instruction manual of the projector.  
[https://eww.pavc.panasonic.co.jp/projector/extranet/main/products/vz570/manual/vz575n\\_en.pdf](https://eww.pavc.panasonic.co.jp/projector/extranet/main/products/vz570/manual/vz575n_en.pdf)

### OPERATION SPECIFICATIONS / FEATURES

- DMX-512 control over 14 DMX channels
- DMX IN / OUT port (5-pin male and female XLR connectors)
- Art-Net™ connection (RJ45) (Art-Net™ Designed by and Copyright Artistic Licence Holdings Ltd.)
- Mirror Tilt modes: 90° & 162°
- Mirror Panmode: 180°
- High resolution micro step motors with maintenance free direct drive
- Self calibrating mirror position for high accuracy
- Absolut reposition accuracy <0,03°
- Movement accuracy: Pan and Tilt from the same direction to the programmed point within approximately 0,01°
- RS232 remote control connection for projector (D-sub 9 male) - cable included
- Flashable firmware (Mini USB)
- High resolution LED-Display for easy configuration
- LED-Display backlight auto turn off for energy saving
- LED-Display Flip / Flop mode for easy reading in difficult positions
- Coated mirror for optimum reflection ~98% refraction factor
- Optimized mirror optics for the specific projector
- Ambient Light LED with high power 3 Colour LEDs (17,9 Watt total)
- High durability black powder-coating surface finishing
- Mounting plate optimized for specific projector mounting
- Easy to adjust mounting system
- Heavy-use truss or wall mounting supports
- Passive cooled system (excluding projector)
- Environmental tolerances: Ambient operating temperature range: 5°-35°C, Humidity: 20%-80% (non-condensing)
- Package includes: RS232 cable, AC-loop through cable, Quick installation guide



To protect the environment, please try to recycle the packing material as much as possible.

