

Mirror Head Manual

Manual for MH29 / MH30

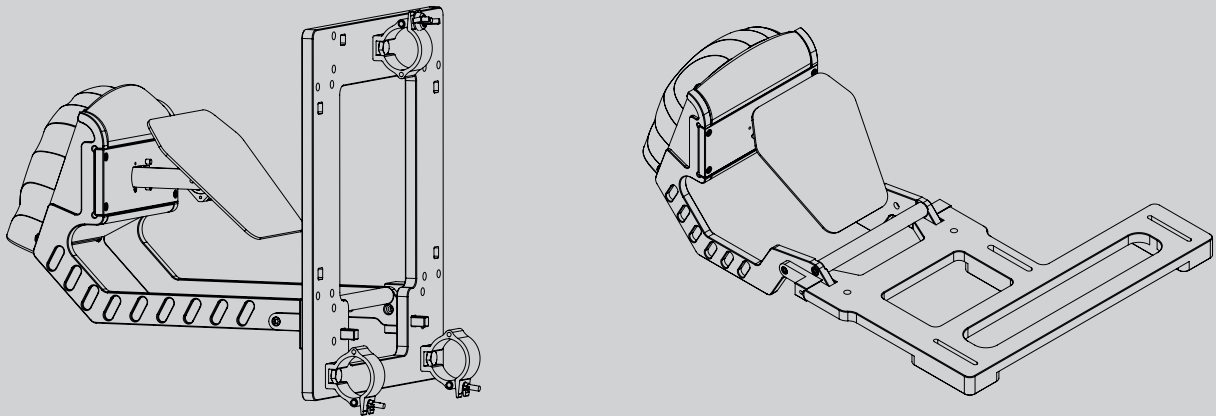

VERSION: 2.8

Table of contents

Introduction	3
Warranty	3
Safety	4
Operating determinations	5
Package contents	6
Technical specifications	6
Description of the device	7
Mirror Head control unit	9
Mirror Head assembly	10
Mounting of the projector	11
Mounting of accessories	13
Mounting of the Mirror Head	14
Setup and adjustment	15
Using and Operations (DMX512 / Art-Net™)	16
Mirror Head control unit operations	18
Service and maintenance	20
Trouble shoot / FAQ	21
Compliance	23
Appendix for Mirror Head manual	24

Introduction

Thank you for having chosen a Mirror Head unit. If you follow the instructions given in this manual, we are sure you will enjoy this device for a long period of time.



For your own safety, please read this user manual carefully before you initially start-up.
Every person involved with the installation, operation and maintenance of this device has to:

- be qualified
- follow the instructions of this manual
- consider this manual to be part of the total product
- keep this manual for the entire service life of the product
- pass this manual on to every further owner or user of the product
- download the latest version of the user manual from our website

In case you have questions about our product or need support during assembly and installation please contact our support!

Dynamic Projection Institute, Herstellungs und Vertriebs GmbH
Josef Schleps Straße 5 - Halle A04 / 2104 Spillern - Austria
Email: office@dynamicprojection.com
Web: www.dynamicprojection.com
Phone: +43 1 996 2028 (Mon. – Fri. from 8:00 – 17:00h)
Commercial Register: FN400806x

Warranty

DPI represents and warrants:

- that all products will be in a fully working and commercially available condition.
- for twelve (12) months from the date of proof of purchase by a customer, unless otherwise agreed.

Warranty is void if the operator of the Mirror Head violates any safety and/or operation advice in this manual.

Safety

This device has left our company in absolutely perfect condition. In order to maintain this condition and to ensure a safe operation, it is absolutely necessary for the user to follow the safety instructions and warning notes written in this user manual.

NOTE: Damages caused by the disregard of this user manual are not subject to warranty. The dealer will not accept liability for any resulting defects or problems.

Never look directly into the light source of an attached projector!

Keep away from children!

There are no user serviceable parts (fuse) inside this unit.

If the device has been exposed to drastic temperature fluctuation, do not switch it on immediately. The arising condensation water might damage your device. Leave the device switched off until it has reached room temperature.

Please make sure that there are no obvious transport damages. Should you notice any damages on the A/C connection cable or on the control unit, do not take the device into operation and immediately consult your dealer.

This device falls under protection-class I. The power plug must only be plugged into a protection class I outlet. The voltage and frequency must exactly be the same as stated on the device. Wrong voltages or power outlets can lead to the destruction of the device and to mortal electrical shock.

Always plug in the power plug last. The power plug must always be inserted without force. Make sure that the plug is tightly connected with the outlet.

Never let the power-cord come into contact with other cables! Handle the power-cord and all connections with the mains with particular caution! Never touch them with wet hands, as this could lead to mortal electrical shock.

Never modify, bend, strain mechanically, put pressure on, pull or heat up the power cord. Never operate next to sources of heat or cold. Disregard can lead to power cord damages, fire or mortal electrical shock.

The cable insert or the female part in the device must never be strained. There must always be sufficient cable to the device. Otherwise, the cable may be damaged which may lead to mortal damage.

Make sure that the power-cord is never crimped or damaged by sharp edges. Check the device and the power-cord from time to time.

If extension cords are used, make sure that the core diameter is sufficient for the required power consumption of the device. All warnings concerning the power cords are also valid for possible extension cords.

Always disconnect from the mains, when the device is not in use or before cleaning it. Only handle the power-cord by the plug. Never pull out the plug by tugging the power-cord. Otherwise, the cable or plug can be damaged leading to mortal electrical shock. If the power plug or the power switch is not accessible, the device must be disconnected via the mains.

If the power plug or the device is dusty, the device must be taken out of operation, disconnected and then be cleaned with a dry cloth. Dust can reduce the insulation which may lead to mortal electrical shock. More severe dirt in and at the device should only be removed by a specialist.

There must never enter any liquid into power outlets, extension cords or any holes in the housing of the device. If you suppose that also a minimal amount of liquid may have entered the device, it must immediately be disconnected. This is also valid, if the device was exposed to high humidity. Also if the device is still running, the device must be checked by a specialist if the liquid has reduced any insulation. Reduced insulation can cause mortal electrical shock.

There must never be any objects entering into the device. This is especially valid for metal parts. If any metal parts like staples or coarse metal chips enter into the device, the device must be taken out of operation and disconnected immediately. Malfunction or short-circuits caused by metal parts may cause mortal injuries.

Operating determinations

The Mirror Head is a projector add-on device for creating decorative effects. This product is only allowed to be operated with:

- **the voltage labeled on the device**
- **the projector that the product is specified for**
- **the original accessories and add-on parts**

The device is designed for indoor use only.

This device is designed for professional use only.

Do not shake or drop the device. Avoid brute force when installing or operating the device. Take special care of the mirror.

When choosing the installation-spot, please make sure that the device is not exposed to extreme heat, moisture or dust. In order to safeguard sufficient ventilation, leave 0.5m of free space around the device.

This device must never be operated or stockpiled in surroundings where splash water, rain, moisture or fog may harm the device. Moisture or very high humidity can reduce the insulation and lead to mortal electrical shocks.

When using smoke machines, make sure that the device is never exposed to the direct smoke jet and is installed in a distance of at least 1.0 meters between smoke machine and device.

The ambient temperature must always be between +5°C and +35°C. Keep away from heaters and air-condition ventilations. The relative humidity must not exceed 80% with an ambient temperature of +35°C. The maximum ambient temperature $T=35^{\circ}\text{C}$ must never be exceeded.

Never use the device during thunderstorms. Over voltage could destroy the device. Always disconnect the device during thunderstorms.

This device is only allowed for an installation via the original mounting brackets or clamps.

Do not mount projectors to this unit that this unit was not designed for.

Make sure that the area below the installation place is blocked when rigging, de-rigging or servicing the fixture.

To prevent any damage to equipment or physical injury the installation should be carried out by at least two persons.

Always fix the fixture with an appropriate safety bond depending on the weight of the whole fixture.

For the use of closed-type riggings such as half-coupler clamps

secure the fixture with a safety cable (or other secondary attachments) that is approved for the weight of the fixture, so that the safety cable will hold the fixture if the primary attachment fails.

It is important to select the mounting position of the Mirror Head before starting the assembly.

The fixture can be clamped to a truss or similar rigging structure in any orientation using one or more closed-type rigging clamps such as half-coupler clamps that completely enclose the truss chord. Only use certified equipment.

Operate the device only after having become familiarized with its functions. Do not permit operation by persons not qualified for operating the device.

Never use solvents or aggressive detergents in order to clean the device especially the mirror. Rather use a soft and damp cloth. Do not scratch or touch the surface of the mirror with any object or by touching with the fingers.

Please use the original packaging if the device is to be transported. Make sure that you pack the device in the original state.

Please consider that unauthorized modifications on the device are forbidden due to safety reasons!

Never remove the serial from the device as this would make the guarantee void.

If this device will be operated in any way different to the one described in this manual, the product may suffer damages and the guarantee becomes void. Furthermore, any other operation may lead to dangers like short-circuit, burns, electric shock, crash etc.

Package contents

Immediately upon receiving a fixture, carefully unpack the box, check the contents to ensure that all parts are present, and have been received in good condition. Notify the shipper immediately and retain packing material for inspection if any parts appear damaged from shipping or the box itself shows signs of mishandling.

Save the box and all packing materials. In the event that a fixture must be returned to the factory, it is important that the fixture be returned in the original factory box .

Before starting to assemble the product please check the contents of the package - see package list inside of the package.

Technical specifications

- High resolution 16bit Pan/Tilt mirror movement
- DMX-512 control over 14 DMX channels
- DMX-IN and DMX-OUT/Through port (5-pin male and female XLR connectors)
- 14 DMX channels are required to control the unit
- Art-Net™ connection (RJ45) (Art-Net™ designed by and Copyright Artistic License Holdings Ltd.) - OEM code 0x1140
- HTTP Control protocol
- High resolution micro step motors with maintenance free direct drive
- Self calibrating mirror position for high accuracy
- Absolute reposition accuracy smaller than 0.03°
- Movement accuracy: Pan and Tilt from the same direction to the programmed point within approximately 0.01°
- RS232 remote control connection for projector (D-sub 9 male) - cable included
- Flash-able firmware (Mini USB OTG)
- LED-Display for easy configuration
- Coated mirror for optimum reflection ~98% refraction factor
- Optimized mirror optics for the specific projector
- Ambient Light LED with high power RGB LEDs (17,9 Watt total) - see compatibility list if available for your model (MH08-MH13)
- Mounting plate optimized for specific projector mounting
- Easy to adjust mounting system
- Passive cooled system, fanless (excluding projector)
- Environmental tolerances: Ambient operating temperature range: 5°–35°C, Humidity: 20%–80% (non-condensing)
- DPCC web interface for easy show creation

Description of the device

The Mirror Head is a modern high-tech mirror that is digitally operated and is used as an add-on feature for projectors. It can be set to move either rapidly or slowly to project pictures, videos and texts onto any imaginable surface. Projections can be moved around from one surface to another or remain statically projected onto one specific surface. Through its high level of performance, the entire system guarantees highly accurate positioning. Please make yourself familiar with the parts of your product and identify your model in the list below.

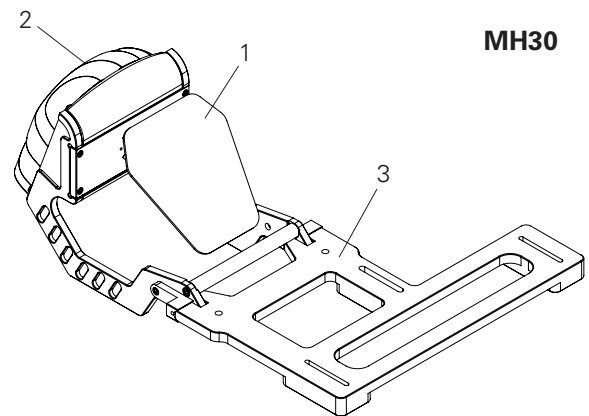
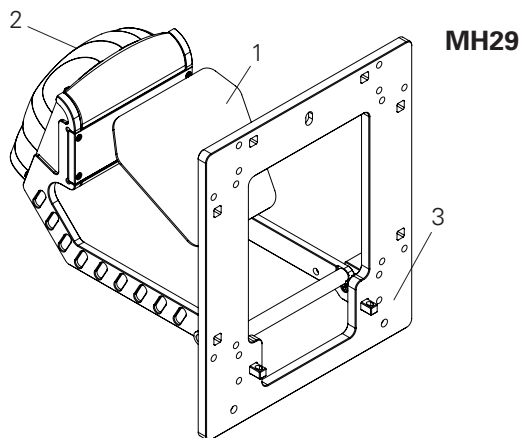

1. Surface coated mirror
2. Mirror Head control unit
3. Mirror Head base plate

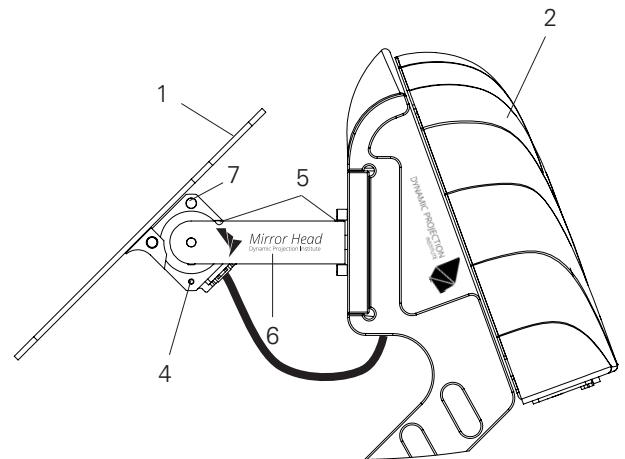
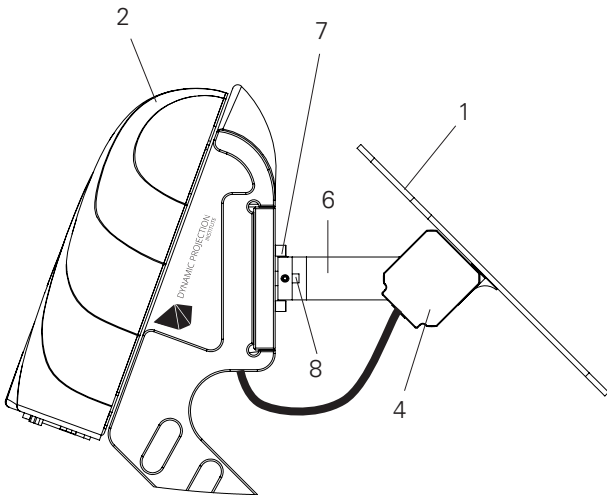

1. Surface coated mirror
2. Mirror Head control unit
3. Mirror Head base plate
4. Tilt motor
5. Reference magnets
6. Motor-drive-arm
7. Reference screws
8. Pan drive shaft

Mirror Head control unit / MHE01

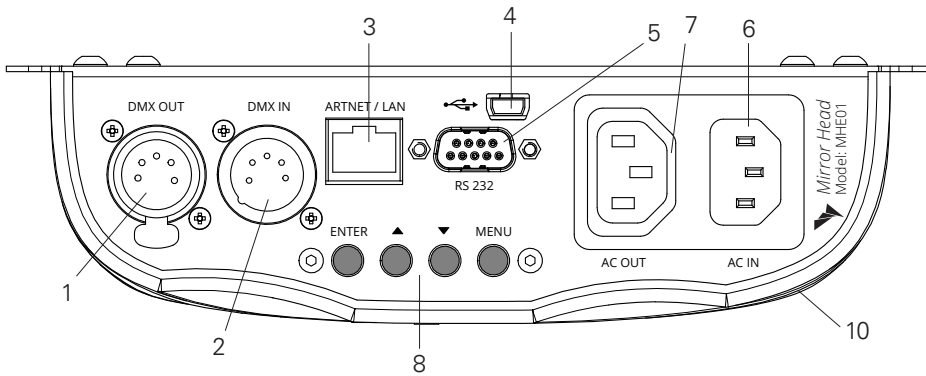

Backside view

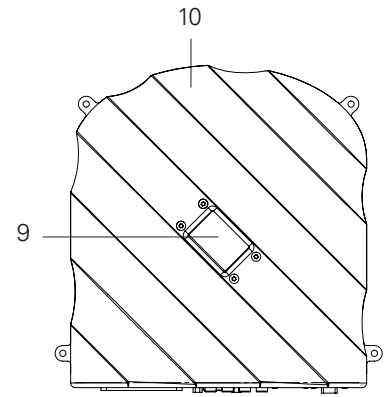

Top view

1. DMX-OUT / Through Socket - 5 Pins XLR
2. DMX-IN Socket - 5 Pins XLR
3. Art-Net™ network - 10Mb/s, 100Mb/s
4. Mini USB OTG - for firmware update

5. RS232 connector - male
6. A/C power input; 80 ~ 260V / 47 ~ 63Hz
3-prong C14 male socket
7. A/C power output; loop trough, 3-prong C13
female socket - max. 10A

8. Control buttons for menu navigation
9. LCD display
10. Control unit

Mirror Head assembly

Before starting to mount the Mirror Head to the projector check which model of the Mirror Head you have and follow the instructions carefully.

Only work at a clean working place and avoid any obstacles that can damage the Mirror Head or projector.

You need the following tools to mount the projector:

- Metric Hex key set
- Metric fork key set

All mounting operations must be carried out by a qualified person.

WARNING: The Mirror Head and the projector can be very heavy – use a second person for help.



Mounting of the projector

For further help on assembly please watch our assembly videos:
<http://www.dynamicprojection.com/mirror-head-assembly/>

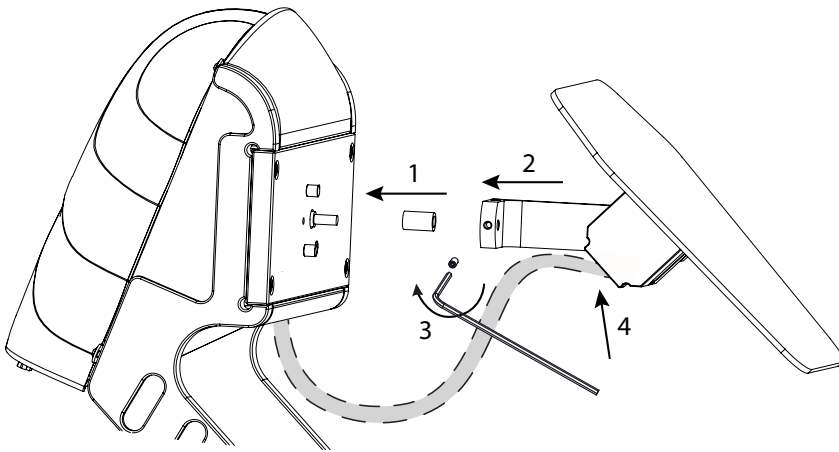

1. Make sure the end-stop (brass part) is over the pan drive shaft. On newer models, this will be pre-installed.
2. Take the whole drive arm end slip it over the pan drive shaft until it reaches the end-stop.
3. Secure the setscrew with the hex key. Make sure that the screw is tightened on the flat side of the D-cut shaft.
Note: The setscrew is pre coated with a thread locking adhesive to lock the screw tight, if a reassembly is required, a new thread locking fluid must be applied.
4. Connect the motor signal cable and fasten the cable on the glue strip with the provided cable tie.

MH29

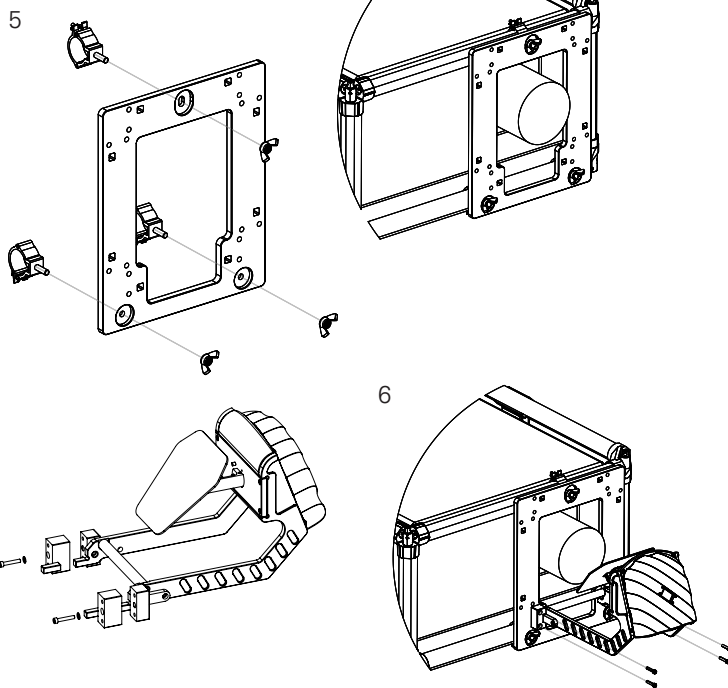

MH30

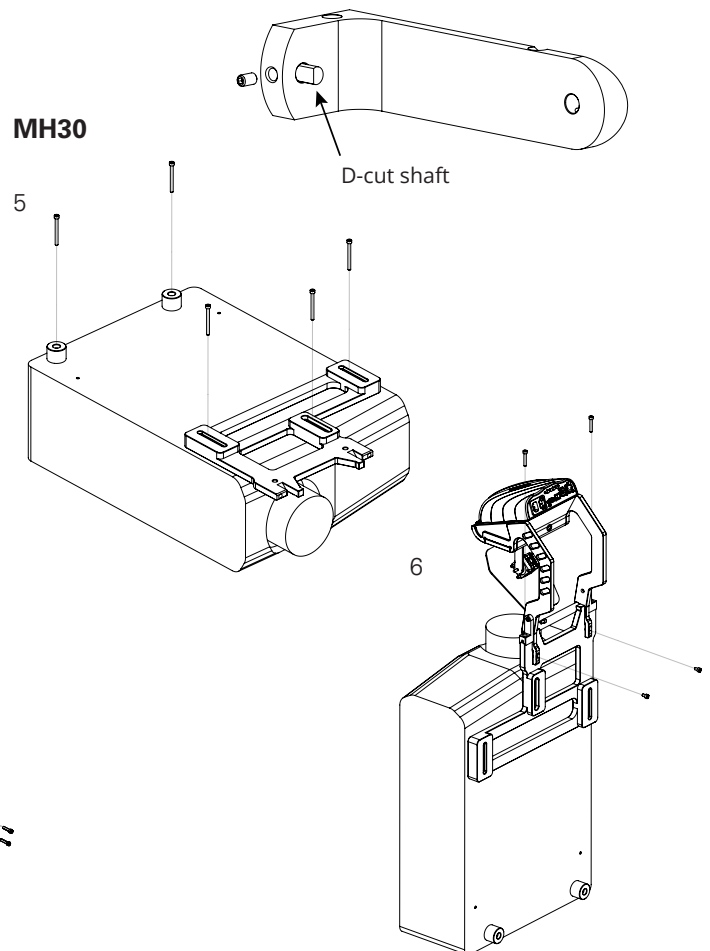

5. Mount the base-plate and the provided accessories to the projector.
WARNING: Secure the projector at any time so it cannot fall out or down. Use a second person to help.
6. Lock-in the Mirror Head arm into the base-plate and secure the two screws at the front and the two screws at the bottom.
NOTE: This step of the installation can be reversed.
7. Connect the RS232 to the projector and to the control unit / MHE01.

Adjust lens shift

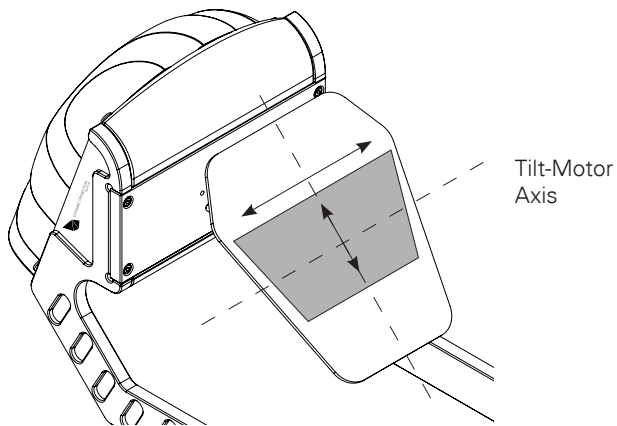

In case your projector is equipped with lens shift, use it to adjust the position (horizontally and vertically) of the projected image on the mirror as shown in the illustration.

Mirror position for adjustment is TILT 45 ° / DMX 128/000, 128/000 in TILT normal mode.

Mounting of accessories

NOTE: This device is only allowed for an installation via the original mounting brackets, clamps or stands.

NOTE: The manufacturer cannot be made liable for damages caused by incorrect installations, unauthorized parts or insufficient safety precautions!

When mounting accessories please follow the installation instructions carefully and read the installation manual of the specific product.
<https://www.dynamicprojection.com/mh-support/>

Mounting of the Mirror Head

The installation must always be secured with a secondary safety attachment, e.g. an appropriate catch net and/or safety cable. This secondary safety attachment must be constructed in a way that no part of the installation can fall down if the main attachment fails.

When rigging, de-rigging or servicing the device staying in the area below the installation place, on bridges, under high working places and other endangered areas is forbidden.

The operator has to make sure that safety-relating and machine-technical installations are approved by an expert before taking into operation for the first time and after changes before taking into operation another time.

The device should be installed outside areas where persons may walk by or be seated. The device has to be installed out of the reach of people.

If the device shall be lowered from the ceiling or high joists, professional trussing systems have to be used. The device must never be fixed swinging freely in the room.

Devices in hanging installations may cause severe injuries when crashing down! If you have doubts concerning the safety of a possible installation, do NOT install the device! Mount the device to your trussing system using an appropriate clamp. For overhead use, always install an appropriate safety bond.

WARNING: OVERHEAD RIGGING REQUIRES EXTENSIVE EXPERIENCE, including (but not limited to) calculating working load limits, installation material being used, and periodic safety inspection of all installation material and the device. If you lack these qualifications, do not attempt the installation yourself, but instead use a professional structural rigger. Improper installation can result in bodily injury and or damage to property.

Examples of positioning the Mirror Head.

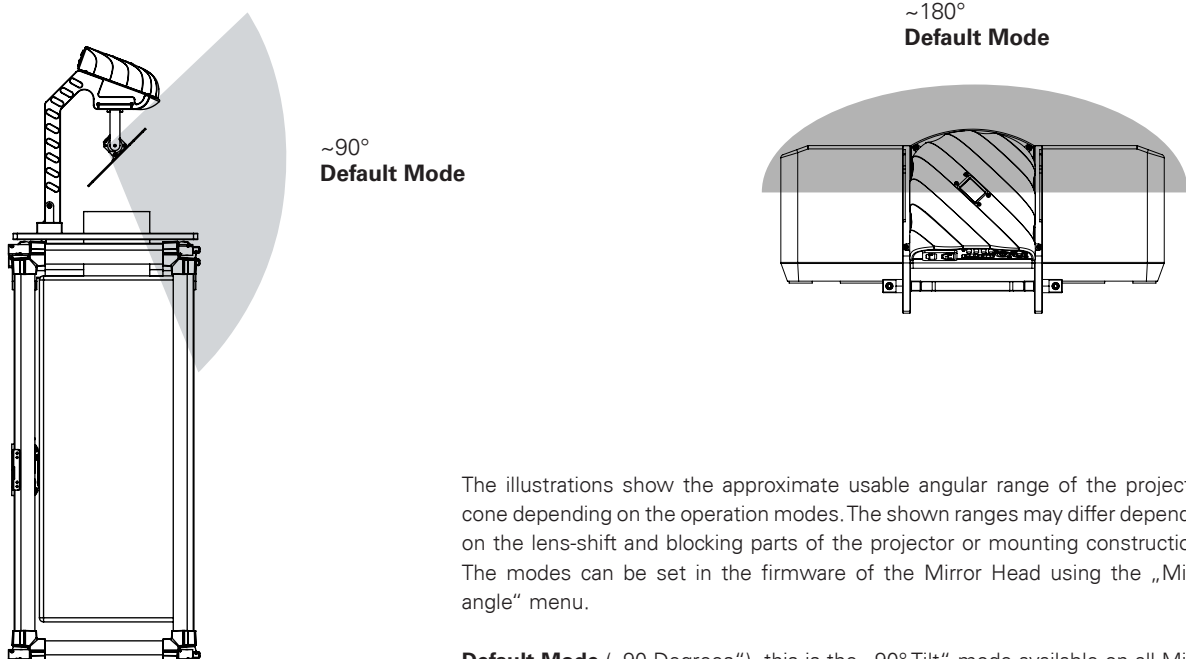

The illustrations show the approximate usable angular range of the projection cone depending on the operation modes. The shown ranges may differ depending on the lens-shift and blocking parts of the projector or mounting constructions. The modes can be set in the firmware of the Mirror Head using the „Mirror angle“ menu.

Default Mode („90 Degrees“), this is the „90° Tilt“ mode available on all Mirror Head models.

Setup and adjustment - Basic connections

Make sure you are:

- familiar with the projector you are using together with the Mirror Head.
- have experience with projections in general

Throw ratio calculation and lenses

Due to optical reasons we do not recommend short throw lenses and lower throw ratio. See our Mirror Head Data and Productsheets for more specific recommendations on throw ratio, depending on the projector and Mirror Head models.

<https://www.dynamicprojection.com/compatibility/>

If your projector does have a lens-shift adjust it so the center of the projection on the mirror aligns with the tilt-motor axis and the pan-motor axis. Of course you can adjust the lens-shift differently if you need it.

The Mirror Head does not change the optical properties of the lens that is used by the projector. For a typical throw ratio calculation you measure the distance from the center of the mirror to the wall you are projecting on and add 0,08m (8cm).

Media Server with Art-Net™ control and video playback

Mirror Head control unit

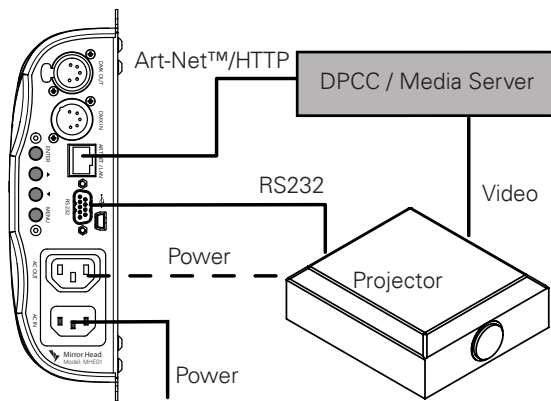

optional — — — — —

This setup shows the combination of the Mirror Head and a Media Server (e.g. MDC-X) that is capable of Art-Net™/HTTP control, video playback and optional geometry effects. For more information about controlling the Mirror Head see the „Using and operations“ section.

Media Player and DMX Light Table

Mirror Head control unit

DMX Light Desk

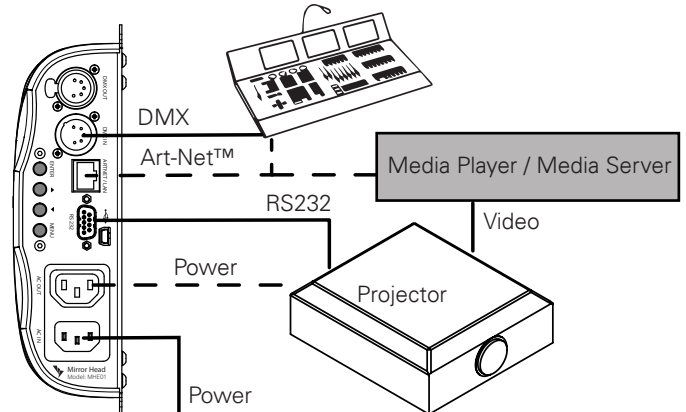

optional — — — — —

This setup shows how the Mirror Head can easily be integrated into DMX-Light Management (DMX512-XLR or Art-Net™) and Media-playback. For more information about controlling the Mirror Head see the „Using and operations“ section.

Using and operations (DMX512 / Art-Net™)

The following instructions are specifically for the firmware version 1.3.26.

To use the Mirror Head as intended, a DMX512/Art-Net™ controller is needed with at least 14 channels.



Caution! Since 2022 all the Mirror Head units are leaving the factory with an entirely **NEW GENERATION OF FIRMWARE 10021**. To download the manual for the new firmware 10021 and newer, please visit our Mirror Head support page.
<https://www.dynamicprojection.com/mh-support/>

General operation information

CAUTION: Never project directly onto people or animals - the light of the projector can cause blindness.

Before starting to mount the Mirror Head make sure:

- **the installation-spot is suited for the Mirror Head.**
- **the mirror can move freely.**
- **there are no vibrations by ventilation systems of any kind.**
- **all screws are secured.**

DMX operations / control

In order to control the Mirror Head at least a 14 channel DMX Master is required. You can find the fixture in the appendix of this document.

The Mirror Head control unit allows you to assign the DMX fixture address, which is defined as the first channel from which the Mirror Head unit will respond to the controller. If you set, for example, the address to channel 15, the device will use the channels 15 to 28 for control.

Make sure that you don't have any overlapping channels in order to control each Mirror Head correctly and independently from any other fixture on the DMX Network.

If two, three or more Mirror Head units have the same DMX address, they will work simultaneously.

NOTE: Two units cannot have the same Art-Net™ IP-address.

Before you start operating you have to decide if you want to control the Mirror Head with DMX-512 (XLR cable) or by Art-Net™ DMX512 (CAT cable, IP layer).

For the most basic operation start to change the values on channel 001 (PAN coarse) and 003 (TILT coarse) - this will move the mirror. If this works try a mirror recalibration by sending the value 255 on channel 004.

NOTE: channel values here assume a DMX address of 1.

The relative center of the mirror (position after power turned on) is equivalent to the DMX values:

DMX channel	DMX value
001	128
002	0
003	128
004	0
...	...

Operations either with DMX-512 or Art-Net™ DMX-512 are equivalent. To get the best movements of the mirror your DMX packet frequency should not be lower than 40Hz.

DMX-512 controlled operation

1. Make sure the unit is turned off.
2. Connect the DMX XLR cable to the DMX-IN socket.
3. Connect the power-cord so the unit turns on.
4. Check the DMX settings in the control unit.
5. Start sending DMX commands and check if the system reacts.

NOTE: It is maybe necessary to insert a DMX / XLR termination plug (with 120 Ohm) in the last unit in the link in order to ensure proper transmission on the DMX data link – please ask your DMX operator.

Art-Net™ controlled operation

1. Make sure the unit is turned off.
2. Connect the power-cord so the unit turns on.
3. Check the DMX settings in the control unit.
4. Check the IP address settings in the control unit.
5. Connect the CAT cable to the control board.
6. Start sending Art-Net™ DMX commands and check if the system reacts.

When the Mirror Head is connected to the network, it can be controlled by sending DMX data over the network using the Art-Net™ protocol. Configure the IP address and netmask according to your network infrastructure (common IP addresses used for Art-Net™ devices are 2.x.x.x or 10.x.x.x) as well as the DMX startaddress (channel offset).

NOTE: If you change the IP address of the unit you have to replug the CAT cable in order to avoid ARP / IP caching of some intermediate switching equipment.

When configured correctly, the device will react to packets sent to IP address itself, the network broadcast address as well as the limited broadcast address 255.255.255.255 - e.g. if the Mirror Head is set to its factory default IP address 2.0.0.3 (netmask 255.0.0.0), packets sent to 2.0.0.3, 2.255.255.255 and 255.255.255.255 may be used to control the Mirror Head.

NOTE: It is recommended to send Art-Net™ packets with a constant data rate of 40 packets per second and “hold” the DMX values for a short amount of time. Sending single packets may not have the intended effect regarding certain projector commands (e.g. lamp on / off) as well as for mirror movement speed – your mileage may vary.

The Mirror Head will honour the DMX channel offset but not the Art-Net™ universe. This means that in setups with multiple Mirror Heads and/or other Art-Net™ compliant devices in multiple universes, the Mirror Heads will react to packets sent to all universes – this can lead to unintentional / unexpected movement / behaviour.

One way to circumvent this problem is by reconfiguring the Mirror Head to use an IP address in a different network, and send the DMX data meant for the Mirror Head only to this network.

However, if the Art-Net™ data is incoming in the form of limited broadcast packets (destination address 255.255.255.255), the network separation by IP address will not work. In this case, the Mirror Head must be physically separated from the network where the data is being transmitted and other means of redirecting the DMX data for the Mirror Head must be used. (e.g. by routing or a proxy)

RS232 projector control

The Mirror Head control unit offers the possibility to send some basic remote control commands to the projector using the RS232 interface.

1. Make sure the projector is turned on and accepts RS232 commands corresponding to the RS232 compatibility list in the appendix.
2. The commands are sent to the projector whenever a specific DMX value is sent on the specific DMX channel – see DMX fixture chart.

Example:

- To turn the projector ON send a value between 230 and 238 on DMX channel 9 for 3 seconds.
- To turn the projector OFF send a value between 250 and 255 on DMX channel 9 for 3 seconds.

Mirror Head Control Unit, MHE01 operations firmware version 1.3.26

The Control Unit of the Mirror Head offers the possibility to adjust the system to the projector and the control environment. The following instructions are specifically for the firmware version 1.3.26. If the visual is any different on your display, refer to the new firmware 10021 and newer, see the manual. <https://www.dynamicprojection.com/mh-support/>

Main screen

The Main-Screen shows the company logo. The back-light of the screen is turned off on default after 30 seconds of inactivity if the system is on this screen. To turn it on again press any of the Mirror Head buttons. On this screen you can change the screen orientation for better handling by pressing special keystroke combinations:

Function	(ENTER)	(UP) ▲	(DOWN) ▼	(MENU)
Display FLIP	X	X	-	-
Display FLOP	X	-	X	-

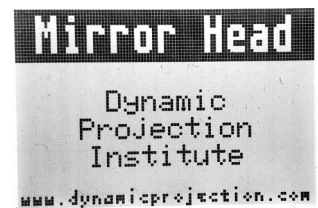

Main menu

This is the top level menu to access all settings of the Mirror Head. You can return to this screen anytime by pressing the (MENU) button. To select an item in the list use the (UP) or (DOWN) buttons and press [ENTER] to access the sub-menu. Inside this menu you can start a mirror-reset (calibration) by pressing the following buttons for 3 seconds.

Function	(ENTER)	(UP) ▲	(DOWN) ▼	(MENU)
Mirror reset	-	X	X	-

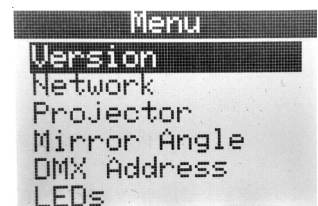

Version

The version menu shows the firmware version of the Mirror Head. The firmware of all Mirror Head products can be upgraded if needed using the USB OTG connector. In this menu you can override the factory default center of the calibration function. Under standard conditions you should never use this function.

Function	(ENTER)	(UP) ▲	(DOWN) ▼	(MENU)
SET Zero Position	X	X	-	-
RESET Zero Position	X	-	X	-



Network

The network interface of the Mirror Head is for Art-Net™ DMX512 communication. Please note that the Mirror Head supports static IP addresses only (DHCP is not supported) and comes with a factory set IP address set to 2.0.0.3, netmask 255.0.0.0. To change the IP-address use the (UP), (DOWN) and (ENTER) buttons. After you changed the IP address press (ENTER) over and over again until you see "DONE" on the top of the screen. Changes will then apply immediately to the network interface of the Mirror Head. To force an ARP update disconnect the network cable for at least 5sec.

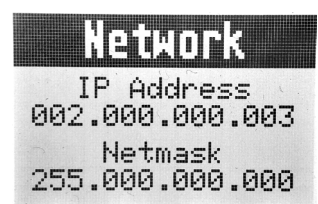

NOTE: Depending on the network infrastructure it is maybe necessary to reset the switches and / or network interfaces of other devices if the IP-address of the Mirror Head changes.

NOTE: Every device in an IP network must have its own IP address.

NOTE: You cannot use Art-Net™ DMX512 and analog DMX at the same time. Changing this physical layer requires a power off-on cycle of the Mirror Head.

Projector

The Mirror Head offers the possibility for a remote control of the projector over DMX via the

RS232 interface. This menu allows you to select the connected projector brand (see Appendix for compatibility and function list) to be used with the Mirror Head. The projector must be connected with the Mirror Head using a RS232 cable and the remote control function must be enabled and set correctly on the projector.

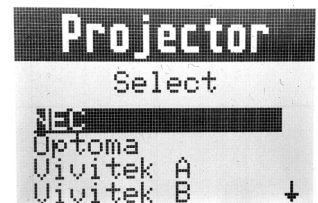

Mirror angle

This option offers you the possibility to change the tilt-axis between Mode-90° and Mode-162° for specific versions of the Mirror Head. Switching between Mode-90° and Mode-162° does not require a restart of the Mirror Head. If you switch the mode the center position on the tilt-axis of the Mirror Head changes.

WARNING: Use the 162° only if your Mirror Head is compatible with this setting – Check the 162° compatibility list in the appendix.

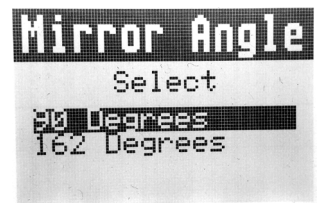

DMX

By default the DMX-Address of the unit starts at 001. Here you can set the offset if you need to change the DMX-Address of this unit. The DMX fixture for the Mirror Head is in the appendix.

NOTE: The Mirror Head unit is always a slave device.

LEDs (MH08–MH13 only)

By default the RGB LEDs of the Mirror Head (if available for your model - see appendix) are controlled over Art-Net™/DMX by selecting the specific RGB and intensity channel values. If the LEDs should be on no matter if there is a DMX signal or not, the fixed values can be set here.

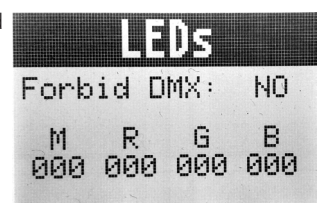

Firmware update

To update the Mirror Head firmware a OTG-mini USB connector cable is needed. The firmware is loaded onto the USB stick and the cable with the USB stick is plugged into the Mirror Head. After this, the Mirror Head shall be turned on. On the display a notice will appear telling that the system is updating. Remove the USB stick and cable after the update is finished.



USB OTG Adapter example

Service and maintenance

NOTE: The Mirror Head does not contain any serviceable parts.

NOTE: Even though the Mirror Head unit does not contain any parts that must be serviced; e.g. lubed, oiled or replaced – we recommend regular inspections.

The operator has to make sure that safety-relating and machine-technical installations are inspected by an expert and skilled person on a regular basis; at least once a year.

The following points have to be considered during the inspection:

- All screws used for installing the devices or parts of the device have to be tightly connected and must not be corroded.
- There must not be any deformations on housings, fixations and installation spots (ceiling, suspension, trussing).
- Mechanically moved parts like axles, cables, motors and others must not show any traces of wearing (e.g. material abrading or damages) and must rotate freely and without force if power is disconnected.
- The electric power supply cables must not show any damages, material fatigue (e.g. porous cables) or sediments.
- Further instructions depending on the installation spot and usage have to be adhered by a skilled installer and any safety problems have to be removed.

Trouble Shoot / F.A.Q.

PROBLEM / ISSUE / QUESTION

SOLUTION / ANSWER

The systems makes a rattling noise when powered on. The mirror shakes violently.

This is a normal operation. The system re-calibrates itself every time the motor regain power. This functionality ensures that the system is position stable even after power failures.

The mirror does not move when i change the DMX values.

Make sure the unit has power. Make sure that the DMX address and the Art-Net™ IP address (if Art-Net™ is used) is correct. Make sure the motor and LED drivers are turned on - if unsure power-cycle the unit or send a „motor drivers on“ command by DMX. Make sure the transport safety is removed. NOTE: Your DMX master must send at least 14 channel in order to be able to control the Mirror Head. Small 4 channel light-desk units do not work.

The mirror lost its position after a power-cycle.

The mirror was accidentally moved by an external force (touched) and lost its position. Always start programming a show only after you did a „mirror-reset“

How do i recalibrate the mirror?

Either send value 255 on DMX channel 005, power-cycle the unit or press the „mirror-reset“ keystrokes in the main menu of the control unit.

The LEDs do not light when i set the DMX values.

Make sure your units does have LED support. Check the menu LED in the control unit and see if LED control over DMX is allowed.

The LCD screen of the control unit does not turn off.

Use the (MENU) button to switch to the main screen. The display will turn off after 30sec.

The image on the wall shakes when the mirror does not move.

Check the ventilation system and settings of your projector. Unbalanced ventilation fans can cause serious oscillations that lead to unstable images. Check the wall/truss/floor/ceiling of the mounting and make sure all parts are stable and do not vibrate.

Whats the best way to clean the mirror?

We recommend not to clean the mirror at all unless the dirt is visible by projecting a white image on the wall. The reduction of brightness by a slight dust layer is in general not even noticeable. If cleaning is needed only use a special surface mirror cleaning cloth and diluted soap water.

The motors get very hot.

The Mirror Head is designed to keep the motors at a specific operation temperature (50-60°) which is normally reached after about 10min.

The mirror center position changes after every power-cycle

Make sure that there is no DMX signal sent to the unit. Check the reference magnets on the motor-drive-arm and make sure there are no metal parts on them. Check the reference screws if they are secured tightly and do not move.

The mirror got broken accidentally, can it be replaced?

Yes, please contact our support for further information.

The motors make a bird singing like noise when moving.

Broken motor driver cable or connection socket problem.
Please contact our support.

The LCD does not show anything when the power-cord is connected.

Check if you have power on the power-cord. If there is power and the unit does not show any response please disconnect the unit and contact our support. Do not use the unit anymore. Do not open the unit - danger of electric shock!

The motors make a high pitched constant noise when standing still.

This is due to the magnetic field inside of the motors. The Mirror Head is designed to avoid this as best as possible. You can try to move the position of the mirror by a few steps over DMX to go into a position where you do not hear it anymore. NOTE: Please keep in mind that during normal operation the Mirror Head is mounted far away from the observer of the projection and the ventilation of the projector and/or the environment is much louder than the sound of the motor.

How much does the Mirror Head influence the throw-ratio?

The Mirror Head does not change the throw ratio at all. For throw-ratio calculations use the distance from the mirror to the wall and then add 0.08m (distance mirror center to lens).

The image turns when the mirror moves from left to right.

This is due to the physics of reflection.

How fast does the mirror move?

The terminal velocity is about 60°/sec.

The projector does not respond when sending lamp on/off or any other command.

Check if you set the correct projector in the control unit. Make sure the Baud-rate settings on the projector are correct and that the serial communication is enabled.



Web: www.dynamicprojection.com
Commercial Register: FN400806x



YouTube Training channel
<http://www.dynamicprojection.com/training/>



Vimeo channel
<https://vimeo.com/dynamicprojection>



Facebook
<https://www.facebook.com/dynamicprojection/>

Supplier's Declaration of Conformity

Model Number: MH08 – MH35

Trade Name: Mirror Head

Responsible Party: Dynamic Projection Institute,
Herstellungs und Vertriebs GmbH

Address: Josef Schleps Straße 5 / Halle A04 2104 Spillern / Austria

Telephone number: +43 1 996 2028

E-mail: office@dynamicprojection.com

FCC Compliance Statement:

This device complies with Part 15 of the FCC rules. Operation is subject to the following two conditions: (1) this device may not cause harmful interference, and (2) this device must accept any interference received, including interference that may cause undesired operation.

FCC Warning:

To assure continued FCC emission limit compliance, follow the attached installation instructions and the user must use only shielded interface cables when connecting to host computer or peripheral devices. Also, any unauthorized changes or modifications to this equipment could void the user's authority to operate this device.

Innovation, Science and Economic Development Canada ICES-003 Compliance Label: CAN ICES-3 B/NMB-3B

Registration of Broadcasting and Communication Equipments: MSIP-REI-1MH-MH-10, MSIP-REI-1MH-MH-18



Industry
Canada

Industrie
Canada

Every information is subject to change without prior notice

Copyright © 2022 by Dynamic Projection Institute Herstellungs und Vertriebs GmbH, Austria

Appendix for Mirror Head

MH29 / MH30

RS232 projector list and functions	I
DMX fixture definition	II
Feature compatibility list	III
Lens compatibility list for BARCO UDX Series	IV
Mounting options	V
Accessories	VI
Technical Productsheets	VII

RS232 Projector list and functions

Current Firmware does not support RS232 control of projectors.

DMX fixture definition for 1.3.26

In order to control the Mirror Head at least a 14 channel DMX Master is required no matter what kind of Mirror Head and/or function of the fixture you use (see section „Using and operations“ for details).

Channel	Function	Value	Destination	Description	
001	Pan high	0 - 255	Mirror motors	Pan High Byte	
002	Pan low	0 - 255	Mirror motors	Pan Low Byte	
003	Tilt high	0 - 255	Mirror motors	Tilt High Byte	
004	Tilt low	0 - 255	Mirror motors	Tilt Low Byte	
005	Reset	255	Mirror motors	Starts mirror recalibration	
006	Picture mute off	0 - 10	RS232 / projector	Disables picture mute	
006	Picture mute on	20 - 30	RS232 / projector	Enables picture mute	
006	Shutter off	40 - 50	RS232 / projector	Disables the mechanical shutter	
006	Shutter on	60 - 70	RS232 / projector	Enables the mechanical shutter	
006	Picture freeze off	100 - 110	RS232 / projector	Disables picture freeze	
006	Picture freeze on	120 - 130	RS232 / projector	Enables picture freeze	
007	Image orientation 1	10 - 63	RS232 / projector	Image orientation mode 1	
007	Image orientation 2	64 - 127	RS232 / projector	Image orientation mode 2	
007	Image orientation 3	128 - 191	RS232 / projector	Image orientation mode 3	
007	Image orientation 4	192 - 255	RS232 / projector	Image orientation mode 4	
008	reserved	-	-	-	
009	Motor and LED drivers on	28 - 38	Mirror motors & LED	Turns the drivers on	
009	Motor and LED drivers off	50 - 58	Mirror motors & LED	Turns the drivers off	
009	Lamp mode 1	130 - 138	RS232 / projector	Lamp power mode 1	
009	Lamp mode 2	150 - 158	RS232 / projector	Lamp power mode 2	
009	Lamp mode 3	170 - 178	RS232 / projector	Lamp power mode 3	
009	Lamp on	230 - 238	RS232 / projector	Lamp lamp on	
009	Lamp off	250 - 255	RS232 / projector	Lamp lamp off	
010	LED intensity	0 - 255	LED	Main intensity of the combined RGB LEDs	available for MH08 – MH13 only
011	LED red	0 - 255	LED	Red LED intensity	
012	LED green	0 - 255	LED	Green LED intensity	
013	LED blue	0 - 255	LED	Blue LED intensity	
014	reserved	-	-	-	

Valid for firmware version 1.3.26

Feature compatibility list

Mirror Head	Weight [kg]	Dimension [mm]	Adapter plate	Ambient LED	Pan & Tilt range
MH29	9	482 x 272 x 463	-	-	180° & 90°
MH30	8	370 x 212 x 278	-	-	180° & 90°

Lens compatibility list for BARCO UDX Series

Article number	R9862010 (+)	R9862020	R9862030	R9862040	R9829997 (+)
Lens type	TLD+ 1.39 - 1.87:1 WUXGA	TLD+ 1.87 - 2.56:1 WUXGA	TLD+ 2.56 - 4.17:1 WUXGA	TLD+ 4,17 - 6,95:1 WUXGA	TLD+ 6,93 - 10,3:1 WUXGA
MHZ-LEU Lens extension	×	—	—	—	×

(+) NOTE: Due to optical reasons we recommend a throw ratio above 1.6:1.

Lens compatibility list for BARCO F80 Series

GLD lens	GLD lens	GLD lens	GLD lens
TR: 1.06-1.42:1 Motorised	TR: 1.43-2.12:1	TR: 1.43-2.12:1 Motorised	TR: 2.12-3.18:1 Motorised

FLD EN11	FLD EN13	FLD EN14	FLD EN16	FLD+ EN41
TR: 1.6-2.32:1 Standard Zoom	TR: 1.24-1.6:1 Wide Angle Zoom	TR: 2.37-3.79:1 Long Throw Zoom	TR: 3.8-6.5:1 Extra Long Throw Zoom	TR: 1.7-2.5:1 Standard Zoom High Resolution

NOTE: Due to optical reasons we recommend a throw ratio above 1.6:1.

Mounting options MH29

The Mirror Head MH29 and its base plate allow four different mounting positions for the Mirror.

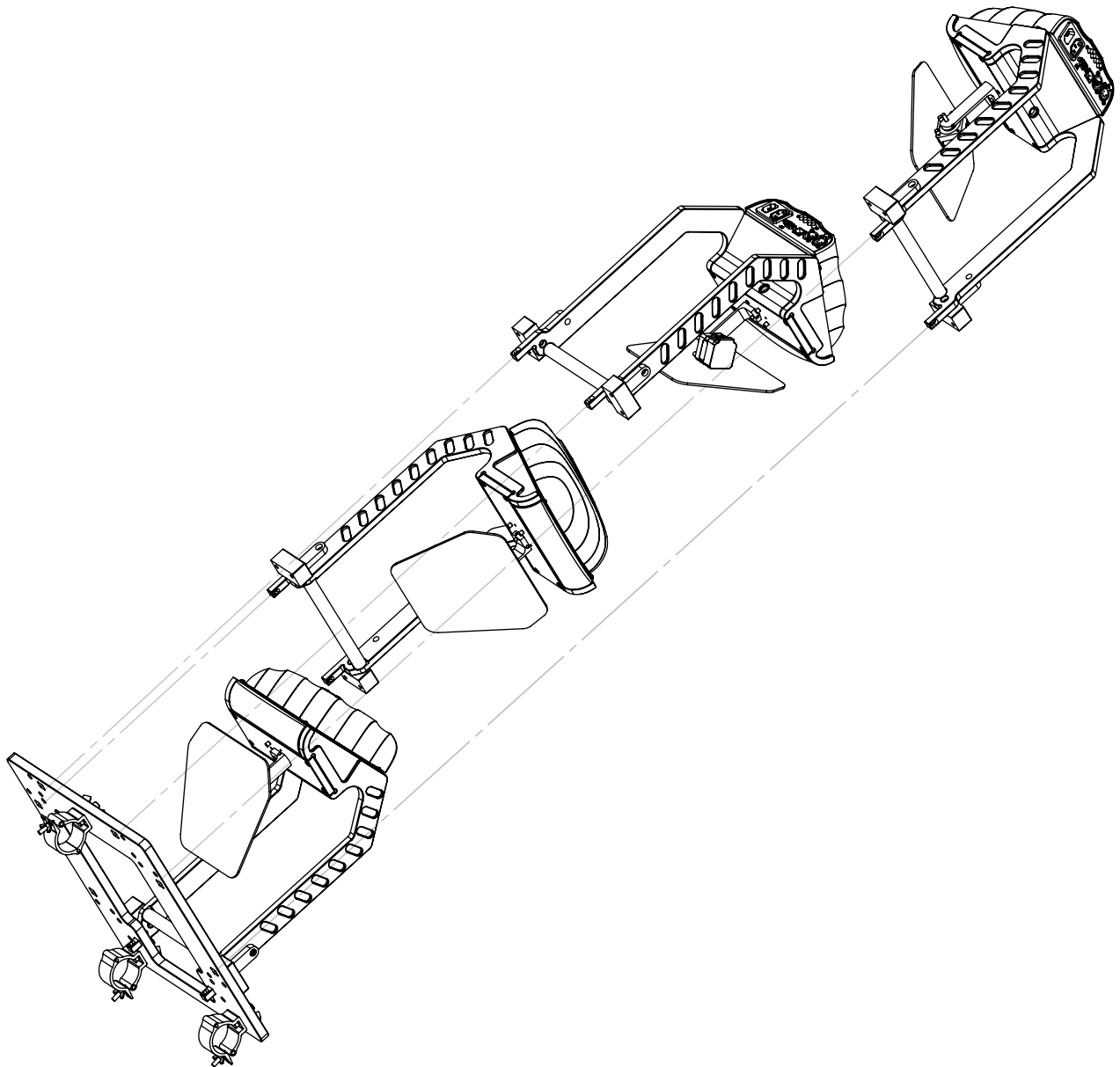

Components:

- (1) 1pcs. Module support with base plate
- (2) 1pcs. Control unit with connection ports and control buttons
- (3) 1pcs. Mechanical mirror drive (PAN / TILT)

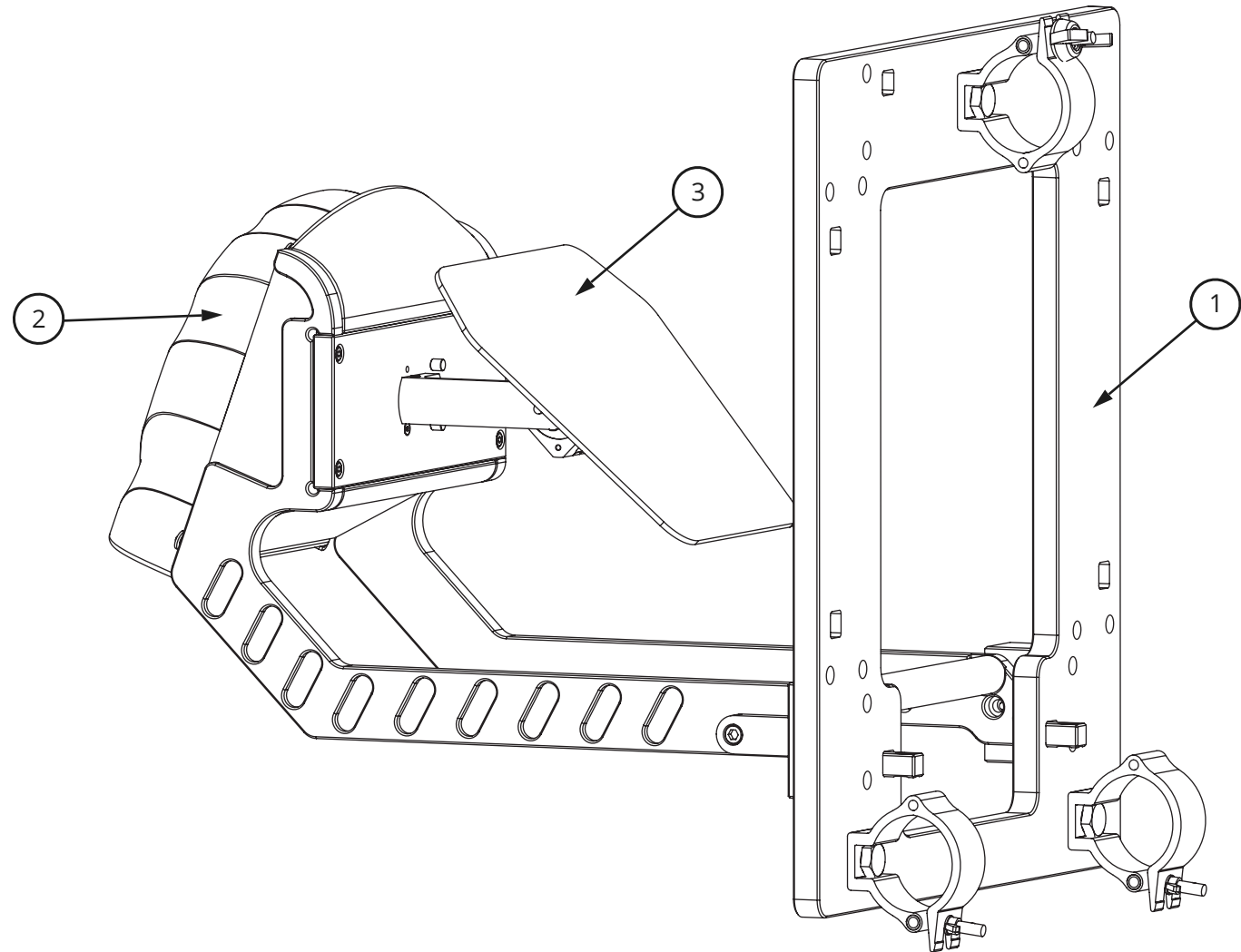
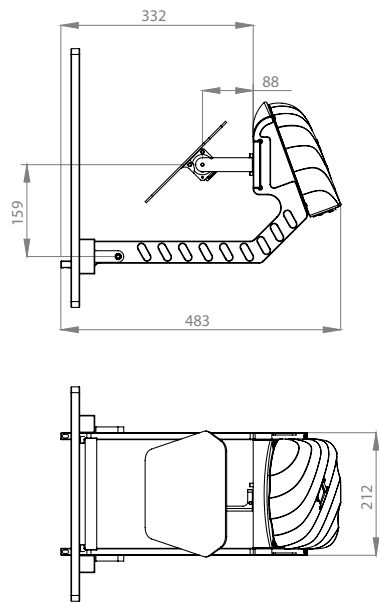

Dimensions: 483 x 212 x 447 mm
Weight: 9 kg

The illustrations may differ in some details from the original.
Subject to change without prior notice.



DYNAMIC PROJECTION
INSTITUTE

office@dynamicprojection.com - www.dynamicprojection.com

Mirror Head / MH29

MH29

2019-07-02

Mirror Head: MH29
Frame: UDX Frame R9801194
Projector: BARCO UDX-4K32
Fixture total: 130 kg

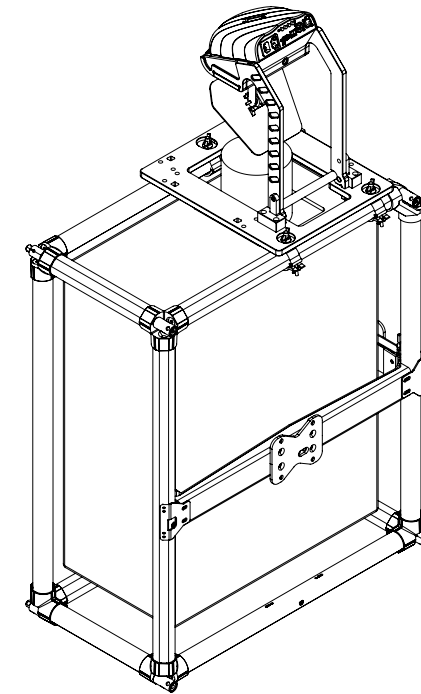
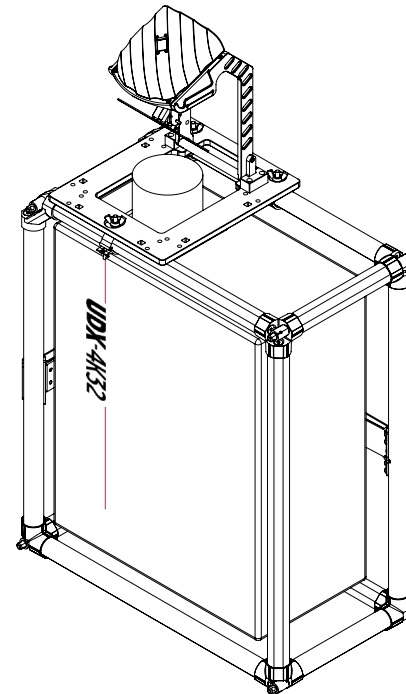
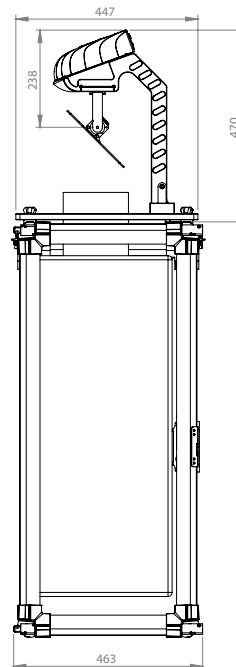
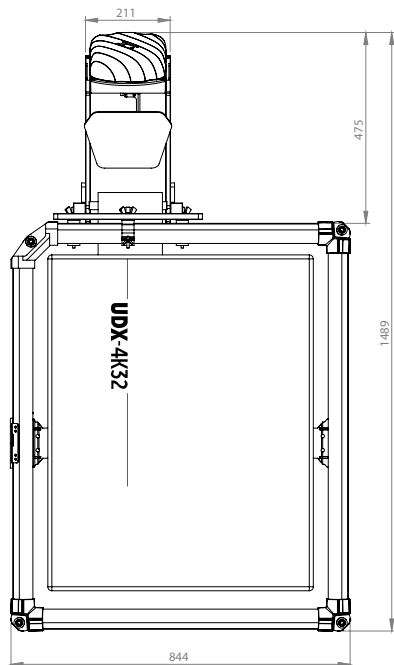
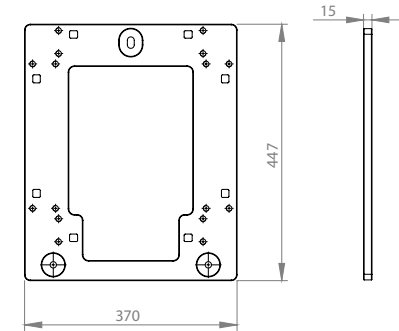

DYNAMIC PROJECTION
 INSTITUTE

office@dynamicprojection.com - www.dynamicprojection.com

Mirror Head / MH29

MH29

2019-07-02

Components:

- (1) 1pcs. Module support with base plate
- (2) 1pcs. Control unit with connection ports and control buttons
- (3) 1pcs. Mechanical mirror drive (PAN / TILT)

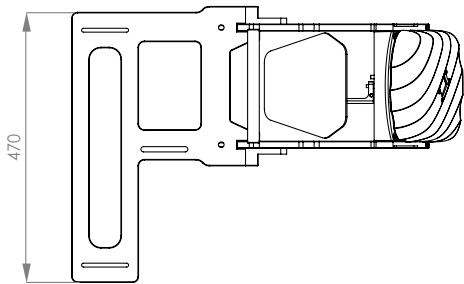
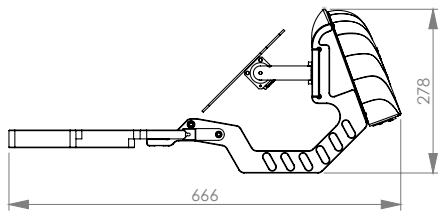
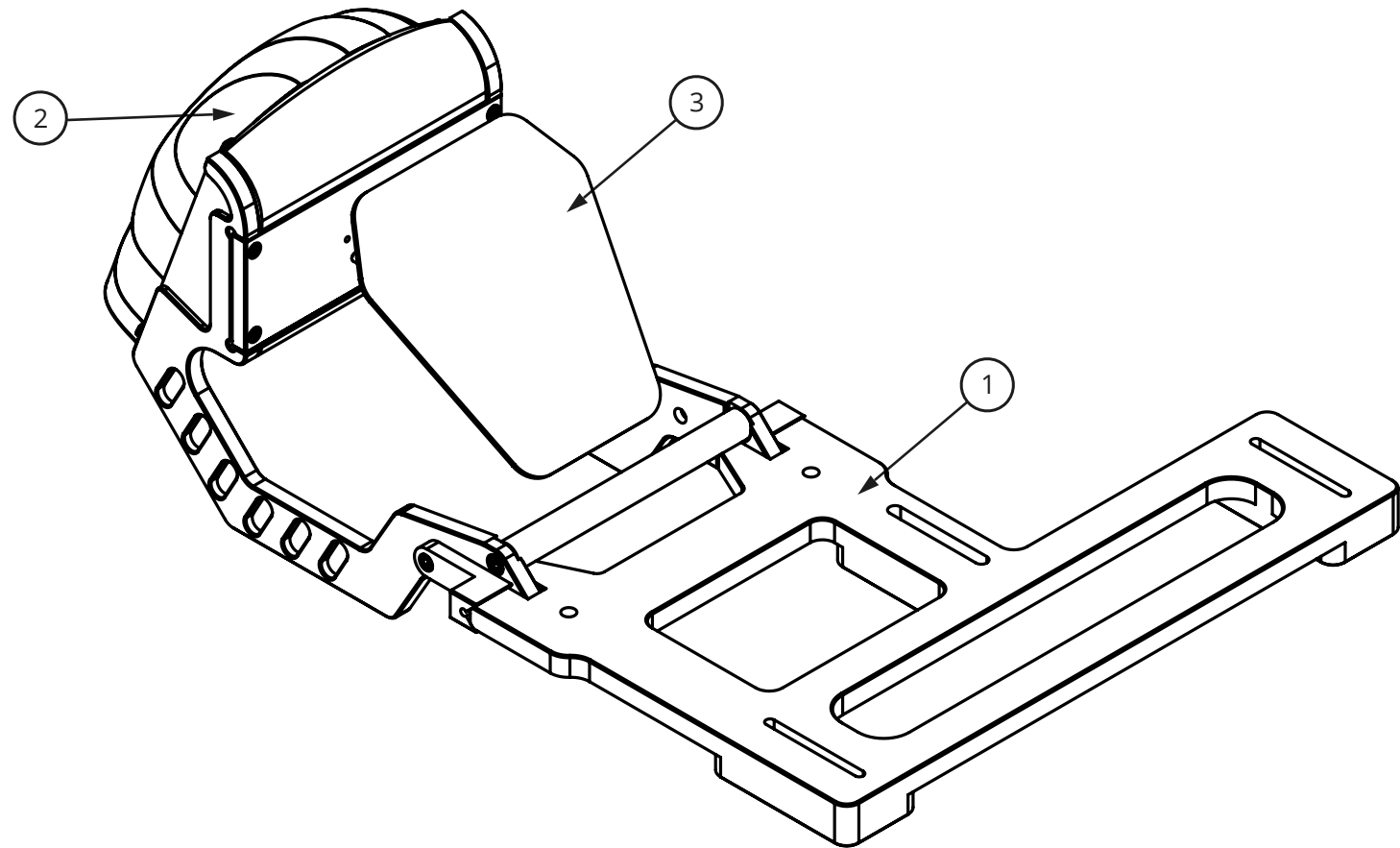

Dimensions: 666 x 470 x 278 mm
Weight: 8 kg

The illustrations may differ in some details from the original.
Subject to change without prior notice.



DYNAMIC PROJECTION
INSTITUTE

office@dynamicprojection.com - www.dynamicprojection.com

Mirror Head / MH30

MH30

2019-10-25

Mirror Head: MH30
Frame: Frame R9802230
Projector: BARCO F80
Fixture total: 37 kg

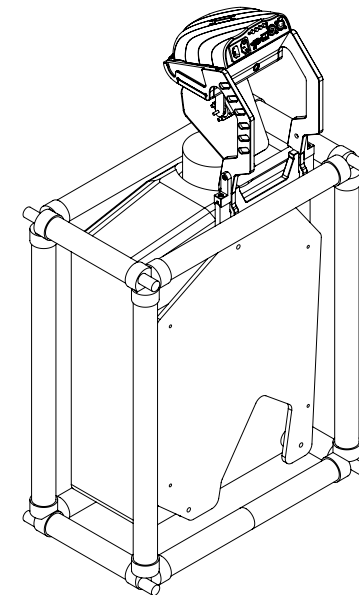
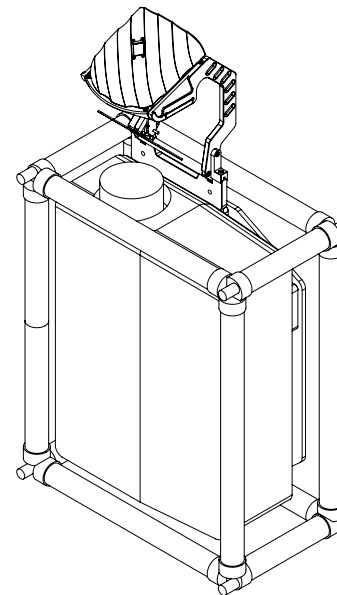
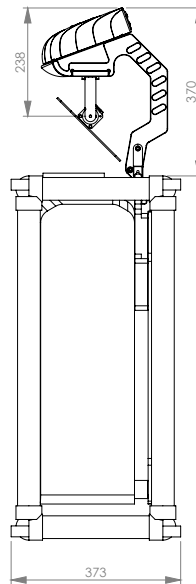
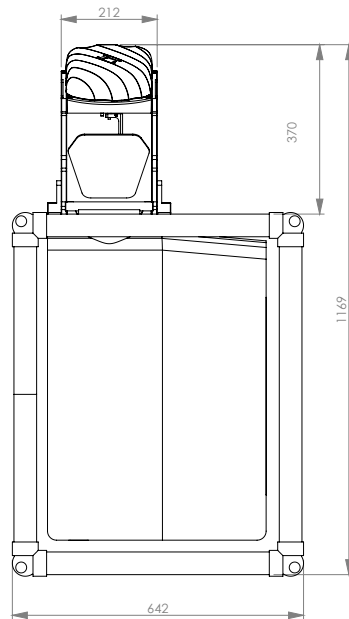
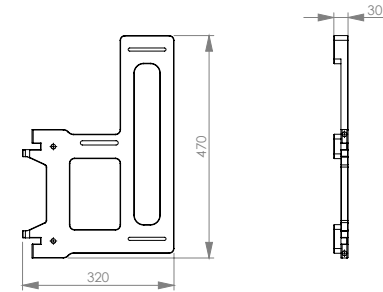

DYNAMIC PROJECTION
 INSTITUTE

office@dynamicprojection.com - www.dynamicprojection.com

Mirror Head / MH30

MH30

2019-10-25

Compatible with:

MH14, MH15, MH16, MH17, MH18, MH19, MH20,
MH21, MH23, MH24, MH25, MH26, MH27, MH28,
MH30, MH33

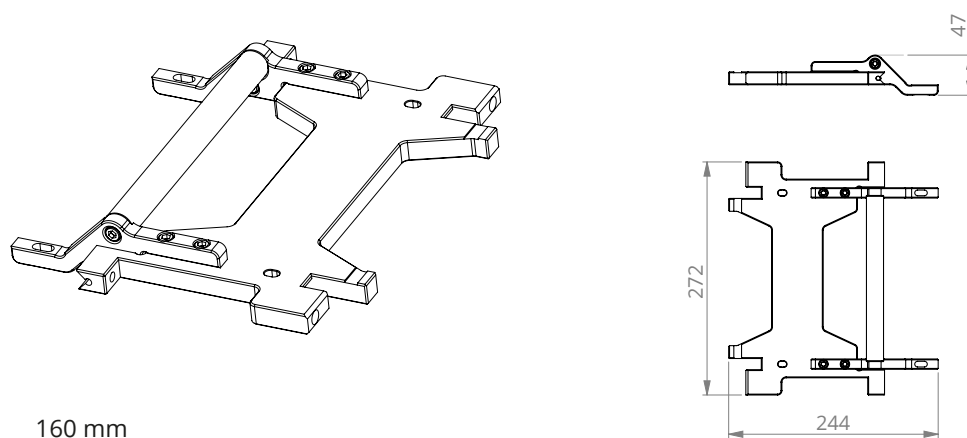
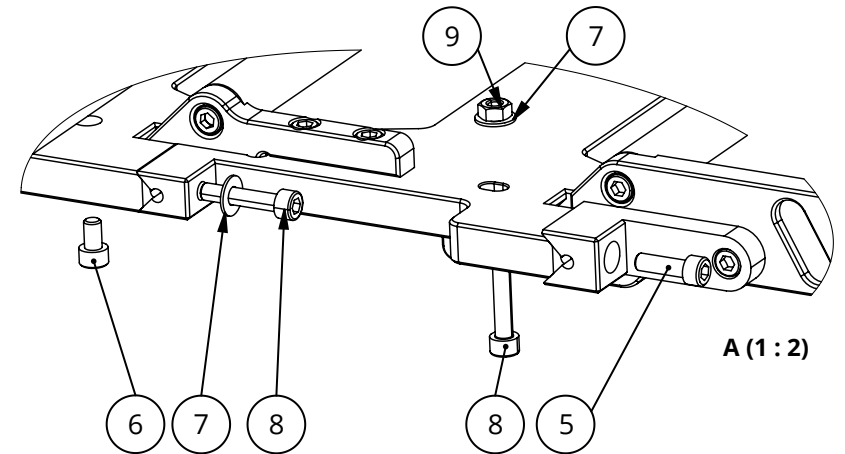
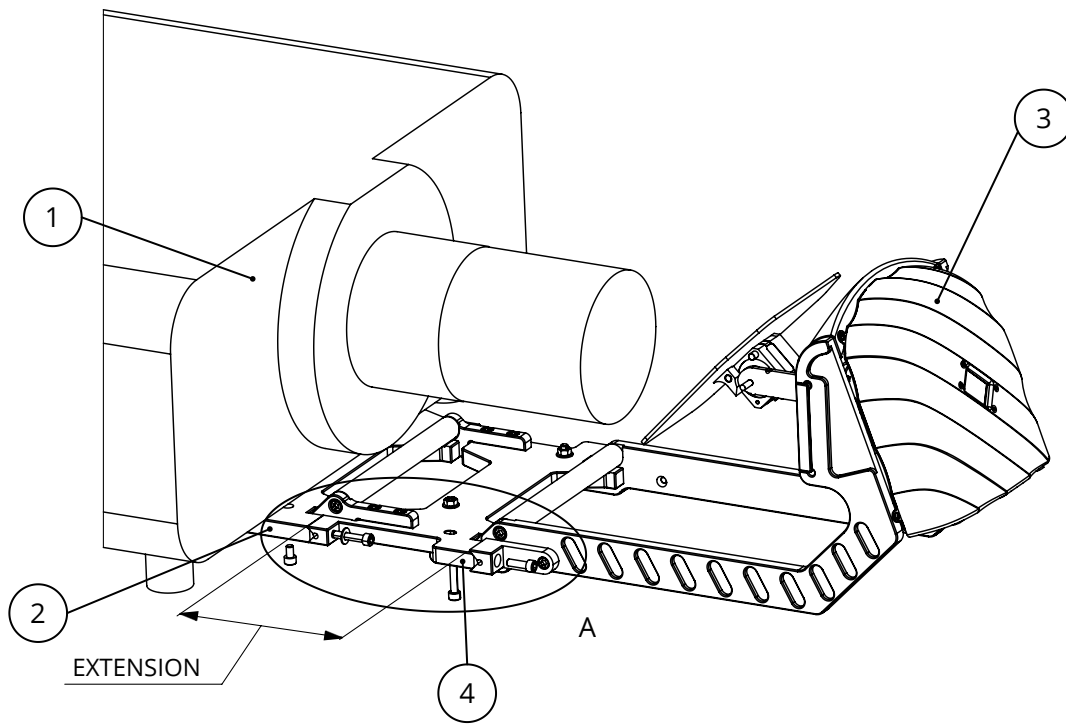

* not included

Extension: 160 mm
Dimensions: 244 x 272 x 47mm (L/W/H)
Weight: 1,3 kg

Nr.	Component	quantity
1*	Projector	1
2*	Mirror Head Baseplate	1
3*	Mirror Head	1
4	Mirror Head Lens Extension	1
5	Screw DIN912 M6*20	2
6	Screw DIN912 M6*10	2
7	Washer M6	4
8	Screw DIN912 M6*30	4
9	Nut M6	2

The illustrations may differ in some details from the original.
Subject to change without prior notice.



DYNAMIC PROJECTION
INSTITUTE

office@dynamicprojection.com - www.dynamicprojection.com

Mirror Head Lens Extension

MHZ-LE8

2018-06-18

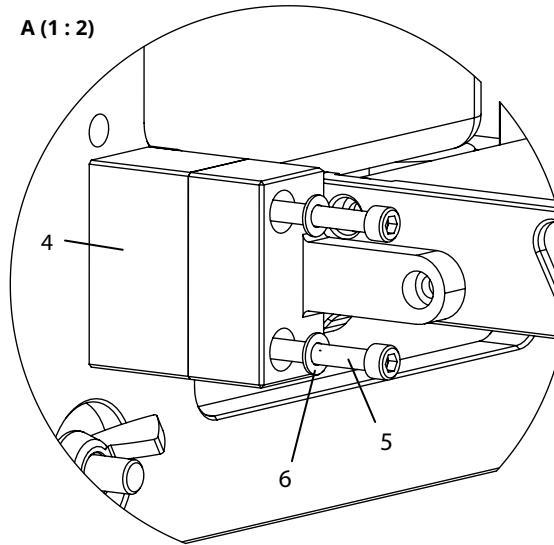
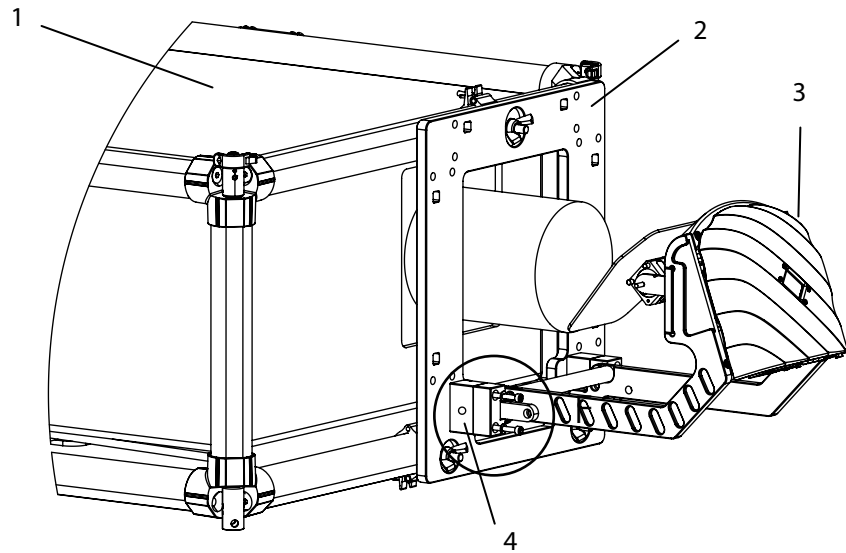

Compatible with:
MH29

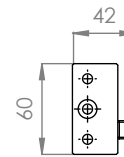
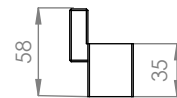
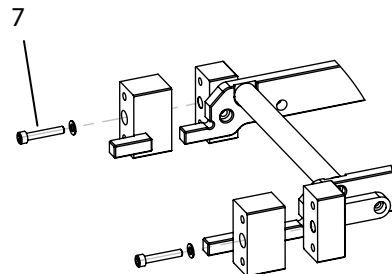
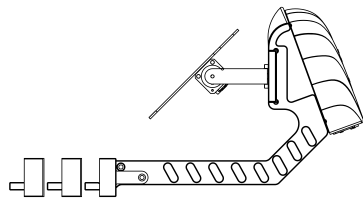
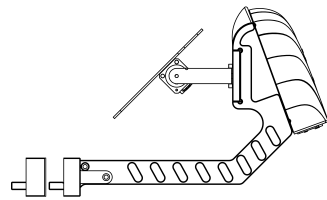
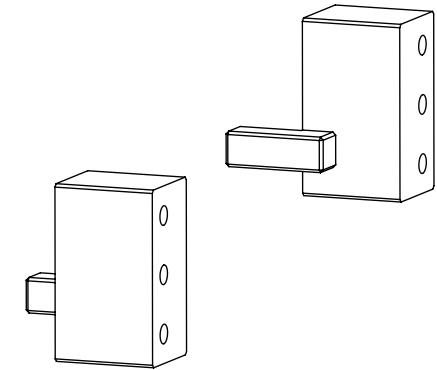

Article number	R9862010	R9862020	R9862030	R9862040	R9829997
Lens type	TLD + (1.39 - 1.87:1 WUXGA)	TLD+ (1.87 - 2.56:1 WUXGA)	TLD+ (2.56 - 4.17:1 WUXGA)	TLD+ (4,17 - 6,95:1 WUXGA)	TLD+ (6,93 - 10,3:1 WUXGA)
Barco UDX Series	1x MHZ-LEU	-	-	-	1x MHZ-LEU
Barco UDM Series	2x MHZ-LEU	1x MHZ-LEU	1x MHZ-LEU	-	2x MHZ-LEU

* not included
** note that a set of lens extension is composed of a left and a right piece

Nr.	Component	quantity
1*	Projector	1
2*	Mirror Head Baseplate	1
3*	Mirror Head	1
4**	Mirror Head Lens Extension	1
5	Screw DIN912 M6*65 / M6*90	4
6	Washer M6	6
7	Screw DIN912 M6*30	2

Extension: 29 mm
Dimensions: 60 x 42 x 54 mm (L/W/H)
Weight: 0,5 kg

The illustrations may differ in some details from the original.
Subject to change without prior notice.



DYNAMIC PROJECTION
INSTITUTE

office@dynamicprojection.com - www.dynamicprojection.com

Mirror Head Lens Extension

MHZ-LEU

2020-01-18